

ProSteel Chalk and Marker Boards feature the new porcelain-on-steel presentation surface with quality and performance characteristics unsurpassed in the marketplace:

- Excellent chalk and marker pen adherence
- Erases easily with soft dry cloth or felt eraser
- Very little glare with minimal surface distortion
- Porcelain Ceramic surface is acid, fire, stain and scratch resistant
- Porcelain Ceramic surface will maintain its qualities for 50 years or the LIFE of its installation
- Requires minimal care and maintenance
- Steel surface holds magnets and magnetic teaching aids
- Resurfacing grade sheets available
- Available in a variety of colors



STANDARD FINISHES

PROSTEEL MARKERBOARD COLORS



605 – Video Blue



002 – Black



826 – Silver



413 – Almond



938 – White

PROSTEEL CHALKBOARD COLORS



001 – Black



814 – Slate



515 – Green



601 – Sapphire

Custom colors are available – call for details
330.668.1515 Fax: 330.668.1513

Product Information

CLEANING and MAINTENANCE RECOMMENDATIONS

An initial cleaning of your ProSteel MARKER or CHALK BOARD should be performed to ensure that no residual film or abrasive residues are present to damage the surface.

Erasing

Use a soft cloth or felt eraser of #2 quality or better.

Writing

Markerboards: use only DRY ERASE MARKERS.

Chalkboards: use CHALK designed for easy erasure. We strongly recommend white chalk with 95% chalk content and only 5% binder. Low dust and color chalks have higher binder content and can leave permanent marks.

Cleaning

Wash your marker or chalkboard periodically to eliminate problems from built up dust or other contaminants.

Markerboards: use any liquid ammonia-added cleaner. RINSE with clear water and DRY your board with a soft towel.

Chalkboards: use clear cool water. RINSE with clear water and DRY your board with a soft towel. Note that the writing and erasing qualities will improve with time as your new product "seasons" through continued use.

General Precautions

Remember, the writing surface is PORCELAIN, and like glass, it will chip and craze if subjected to improper handling.

Because the porcelain surface is impervious to chemical attack, stains from permanent marker, crayon, pen, etc., and tape adhesive residue can be cleaned using the methods described above. For stubborn marks please call for assistance in cleaning your boards.

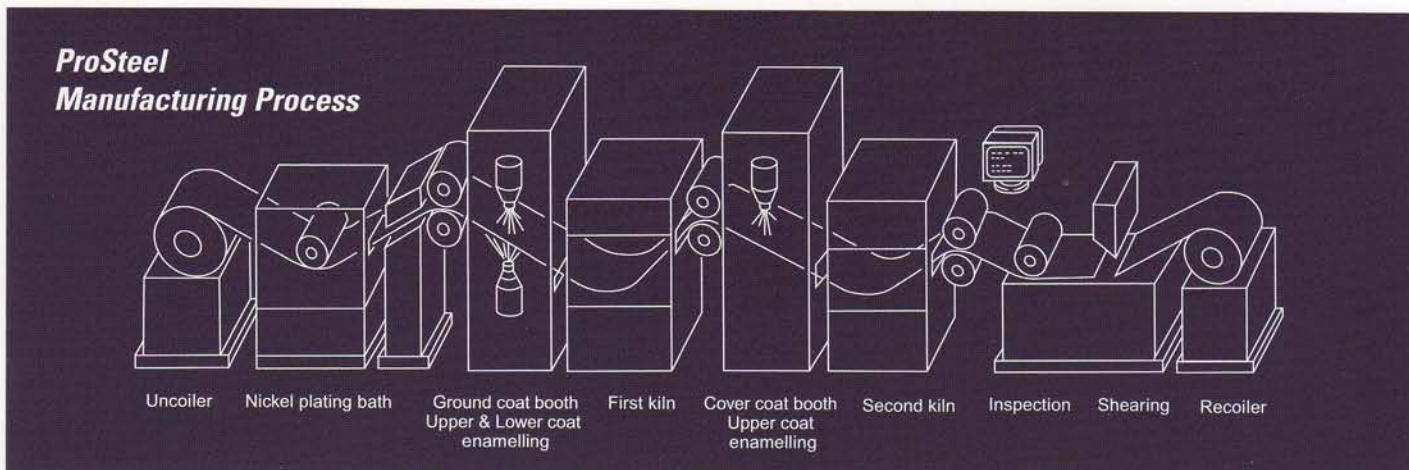

ProSteel Chalk and Marker Board Specifications¹

Coating Thickness	≥ 60 microns face ≥ 15 microns base
Base Material	Ultra Low Carbon Steel 35 mm
Firing Temperature	1400 deg. F (800 deg. C)
Surface Hardness	POH 6.0+
Solvent Resistance	Not Affected
Acid Resistance	Not Affected
Alkali Resistance	Not Affected
Surface Abrasion/Scratch Resistance	60 MG @ 1000 RPM
Surface Smoothness	25-29 Wd Wave Scan

NOTES

¹ Meets or exceeds Porcelain Enamel Institute requirements for the factors listed.

LIMITED WARRANTY

ProSteel is warranted to maintain its original writing and erasing qualities for the next 50 years or the life of its original installation. IN ADDITION, the surface is warranted to remain intact, without crazing, cracking or peeling over the same warranty period. THIS WARRANTY is LIMITED to manufacturer's defects and does not cover malicious destruction, improper handling or maintenance, and use or wear other than the original purpose for which it was intended.

Should a defect occur, the MANUFACTURER will repair or replace, at its discretion, the writing surface. OBLIGATION will be limited to the delivery of repaired or new parts to the original installation site, without charge.

If you should encounter any problem, please contact our office directly, or the office of the installing dealer / contractor.

AVAILABILITY AND ORDERING

ProSteel is available through a network of authorized fabricating distributors. Quality standards are universal. This network allows local attention and service to meet all of your requirements. Please contact K-Pro for the authorized distributor nearest you.

